

210 SOLAR PANEL

EXCEPTIONAL EFFICIENCY AND PERFORMANCE

BENEFITS

High Efficiency

Industry leading panel efficiency of 16.9%

More Power

The SunPower® 210 Solar Panel delivers up to 50% more power per unit area than conventional solar panels.

Reduced Installation Cost

More power per panel means fewer panels per install. This saves both time and money.

Reliable and Robust Design

Proven materials, tempered front glass, and a sturdy anodized frame allow panel to operate reliably in multiple mounting configurations.



The SunPower® 210 Solar Panel provides industry leading efficiency and performance. Utilizing 72 next generation SunPower all back-contact solar cells and an optimized panel design, the SunPower 210 delivers an unprecedented total panel conversion efficiency of 16.9%. The 210 panel's reduced voltage-temperature coefficient and exceptional low-light performance attributes provide outstanding energy delivery per peak power watt.

SunPower's High Efficiency Advantage - Up to Twice the Power

Comparable systems covering 25 m ²		
	Conventional	SunPower
Watts / Panel	165	210
Efficiency	12.0%	16.9%
kWs	3.0	4.2

Electrical Data

Measured at Standard Test Conditions (STC): irradiance of 1000/m², air mass 1.5g, and cell temperature 25° C

Peak Power (+/-3%)	P _{max}	210 W
Rated Voltage	V _{mp}	40 V
Rated Current	I _{mp}	5.25 A
Open Circuit Voltage	V _{oc}	47.7 V
Short Circuit Current	I _{sc}	5.75 A
Maximum System Voltage	IEC	1000 V
Temperature Coefficients		
	Power	-0.38% /°C
	Voltage (V _{oc})	-136.8 mV/°C
	Current (I _{sc})	3.5 mA/°C
Series Fuse Rating		15A
Peak Power per Unit Area		169 W/m ²

Mechanical Data

Solar Cells	72 SunPower all back-contact monocrystalline
Front Glass	3.2 mm tempered
Junction Box	IP-65 rated with 3 bypass diodes
Output Cables	1000 mm length cable / Multi-Contact connectors
Frame	Anodized aluminum alloy type 6063
Weight	15 kg

IV Curve

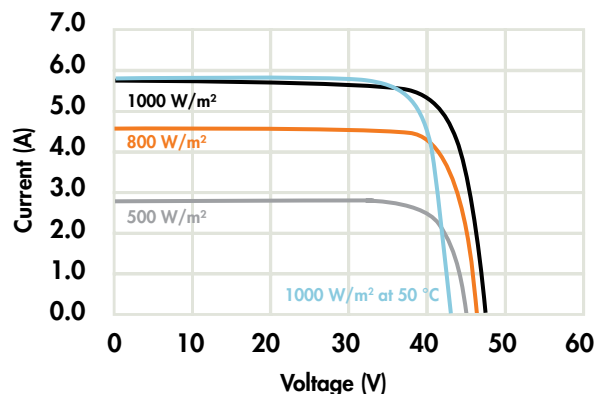

Current/voltage characteristics with dependence on irradiance and module temperature.

Tested Operating Conditions

Temperature	-40° C to +85° C
Max load	240 kg/m ² (2400 Pascals) front and back
Impact Resistance	Hail - 25mm at 23 m/s

Warranty and Certifications

Warranty	25 year limited power warranty 10 year limited product warranty
Certifications	IEC 61215 Ed.2, Safety tested IEC 61730 (SKII)

Dimensions

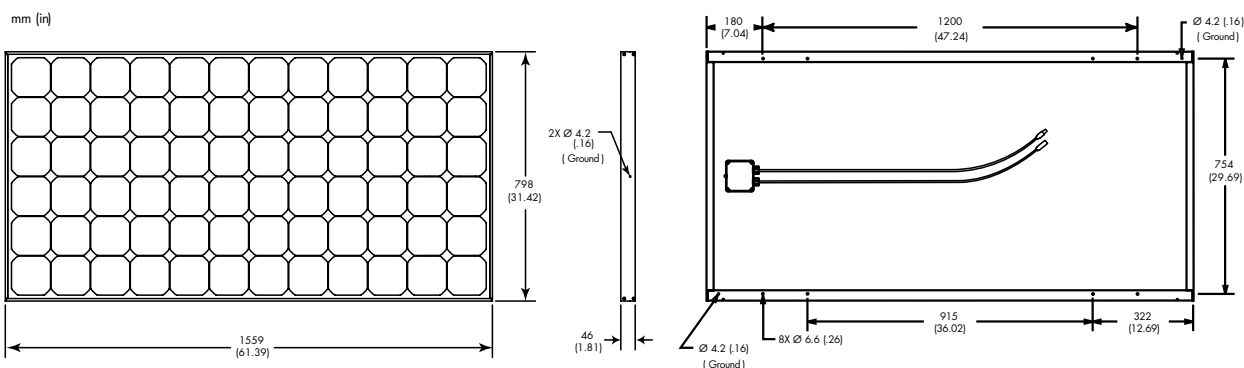

CAUTION: READ SAFETY AND INSTALLATION INSTRUCTIONS BEFORE USING THE PRODUCT. Visit www.sunpowercorp.com for details

About SunPower

SunPower designs, manufactures and delivers high-performance solar electric technology worldwide. Our high-efficiency solar cells generate up to 50 percent more power than conventional solar cells. Our high-performance solar panels, roof tiles and trackers deliver significantly more energy than competing systems.